



AX-M60P
60 QUART PIZZA MIXER

(800) 343-6890 srscooks.com

**SEATTLE
 RESTAURANT
 S♦T♦O♦R♦E**



AXIS
AX-M60P 60 QUART PIZZA MIXER

The Axis Model AX-M60P is an advanced design, highly reliable professional food processing tool, and is specially designed for the task of mixing heavy pizza dough. These call-purpose mixers use a powerful, planetary mixing action to thoroughly blend, mix and aerate all ingredients with consistent and predictable results.

STANDARD FEATURES	STANDARD ACCESSORIES
<ul style="list-style-type: none"> ★ 3 HP motor ★ Reliable and dependable gear drive design ★ Digital Timer (0-30 min) ★ 2 speeds ★ Heat-treated hardened alloy steel gears and shaft ★ Stainless steel bowl guard ★ Front mounted controls (Timer, separate start and emergency stop button) ★ Silent operation ★ Highest quality aluminum alloy used for maximum standards of hygiene ★ Permanent lubricated transmission 	<ul style="list-style-type: none"> ★ 60 Quart S/S bowl ★ Aluminum dough hook ★ Bowl dolly <hr/> <p>OPTIONAL ACCESSORIES</p> <ul style="list-style-type: none"> ★ VS Attachment (<i>housing only</i>) ★ Disks avail. for VS Attachment: (<i>Shredder, grater and slicer disks</i>) <i>Sold separately</i> ★ Meat mincer attachment



Model	Capacity	Motor	Amps	Speeds	Electrical
AX-M60P	60 Quart	2 Speeds	6.2	74 / 125	208v / 60hz / 3ph

TECHNICAL DRAWING

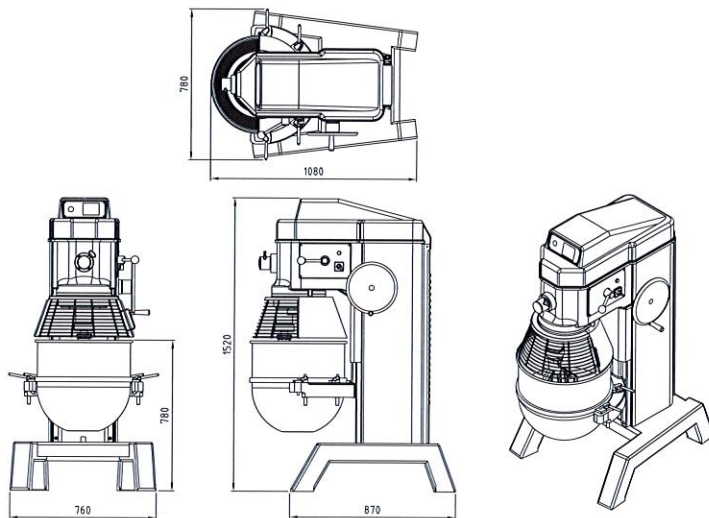

DIMENSIONS

Overall Width = 30.7 (780 mm)
Overall Depth = 42.52 (1080 mm)
Overall Height = 59.84 (1520 mm)

WEIGHT

NET = 992 lbs
SHIP = 1100 lbs

FREIGHT CLASS = 77.5

SPECIFICATIONS

★ Design

Heavy duty all purpose pizza mixers use a powerful, planetary mixing action to thoroughly blend mix and aerate all ingredients with consistent results.

★ Stainless Steel Bowl Guard

Safety interlock prevents operation when front portion of guard is open

★ Two Fixed speeds

Consistency, flexibility and reliability. Excellent for incorporating, blending and mixing ingredients. Provides consistent results throughout mixing. The first speed, of 72 rpm, guarantees an ideal consistency of pizza dough every time.

★ Gear Transmission

Ensures consistent performance and minimum downtime under heavy loads.

★ 3 H.P. Motor

Meets the most demanding operations.

★ Electronic Digital Timer

Provides accurate and consistent results while indicating the length of mixing (in minutes) on digital timer.

★ Warranty

2 year parts and 1 year labor, exclusive of wear items

Due to our continued product improvement and striving for engineering excellence, specifications are subject to change without notice

MVP GROUP CORPORATION

5659 Royalmount Ave. Montreal, QC Canada H4P 2P9
Tel: 514-737-9701 888-275-4538 Fax: 514-342-3854
www.mvpgroupcorp.com / sales@mvpgroupcorp.com