

Curved Glass Bakery Cases

Display Cases
 Bakery Cases - Combination Cases

Patented Self-Cleaning Condenser

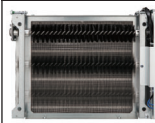

This product is equipped with a fine mesh filter to the front of the condenser to catch dust, and a rotating brush that moves up and down daily to remove excess buildup outward and away.

Model : TCGB-72CO-W(B)-N REFRIGERATED & DRY CASE COMBINATION



* White and black color come standard
 * Image shown here TCGB-60CO-W(B)-N

FEATURES & BENEFITS

Self-Cleaning Condenser

The accumulation of dust in the condenser can cause the failure or breakdown of refrigerators. Refrigerators run normally until they reach a certain level of accumulation. At some point, when they are over the limit, their performance drops quickly resulting in damage to, or disposal of the stored products inside. The Self-Cleaning Condenser device keeps the condenser clean and prevents system failure by automatically brushing daily.

Hydrocarbon refrigerants (R-290)

With innovative and eco-friendly technology, Turbo Air brings you hydrocarbon refrigerators designed to meet DOE's Energy Conservation Standards in 2017 and to use EPA's SNAP Program approved HC refrigerants. Hydrocarbon refrigerants do not deplete the ozone layer and have very low contribution to global warming (ODP-0, GWP-3).

Attractive, elegant, glass sided Euro design

Curved tempered front glass and minimal frame provide full product visibility to optimize display effects. Its elegant contemporary euro design will not only enhance any store atmosphere but also will keep product presentation at its best and most beautiful.

High-density polyurethane insulation

The entire cabinet structure is foamed-in-place using high density, CFC free polyurethane insulation.

Low-E coated double pane glass is tempered for safety

Heavy duty, white PE coated wire shelves

Cantilever wired shelves adjustable up and down, tilted

Stainless steel floor and airflow grille

Sliding rear doors for product loading & unloading

Rear access to compressor compartment for quick and easy service

Refrigerated bakery case holds avg. 33°F ~ 41°F for fresher bakery products



Model	CU./FT.	# of Shelves	HP	AMPS	Crated Weight (lbs.)	L x D x H (inches)
TCGB-72CO-W(B)-N	12.2 x 2	4	1/3	7.5	839	72 1/2 x 34 1/4 x 50 1/8

Model : TCGB-72CO-W(B)-N

ELECTRICAL DATA	
Voltage	115/60/1
Plug Type	Ⓜ NEMA 5-15P
Full Load Amperes	7.5
Compressor HP	1/3
Refrigerant	R-290
DIMENSIONAL DATA	
Net Capacity (cu. ft.)	12.2 x 2
Ext. Length Overall (in.)	72 1/2 (1842mm)
Ext. Depth Overall (in.)	34 1/4 (870mm)
Ext. Height Overall (in.)	50 1/8 (1273mm)
Int. Length Overall (in.)	30 (762mm) x 2
Int. Depth Overall (in.)	27 3/4 (705mm)
Int. Height Overall (in.)	22 3/4 (578mm)
Shelf Size (in.)	(2) 32 7/8 x 15 3/4
	(2) 32 7/8 x 17 3/4
Net Weight (lbs.)	744
Gross Weight (lbs.)	839
# of Shelves	4
Power Cord Length (in.)	59 1/8

Design and specifications subject to change without notice.
Actual shipping weight may differ due to extra packing materials for product protection.

- **WARRANTY :** 2 Year Parts and Labor Warranty
Additional 3 Year Warranty on Compressor

■ STANDARD FEATURES

- Self-contained system, no plumbing required
- Safety shielded LED interior lighting
- Solar powered digital thermometer
- Digital electronic thermostat with defrost control
- White and black colors come standard

- Recommended operating conditions

TCGB models are designed to operate in an environment where temperature & humidity do not exceed 75°F and 55% respectively. Units should not be installed near HVAC vents, fans or doorways that will disrupt the air curtain and compromise the function of the cabinet. Air curtain models will run most efficiently when completely loaded with product.

PLAN VIEW

(unit : inch)

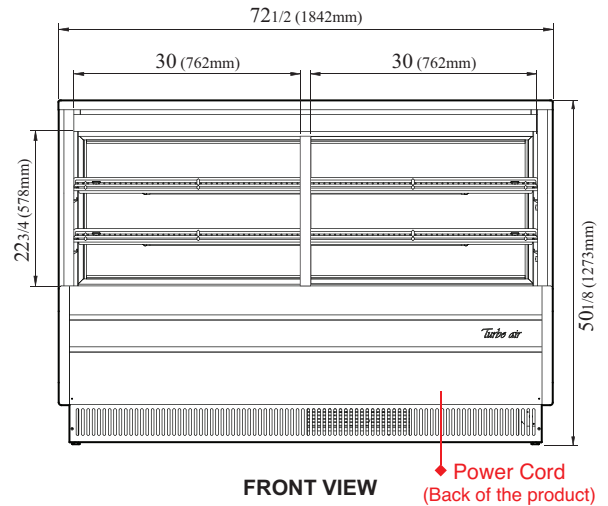

FRONT VIEW

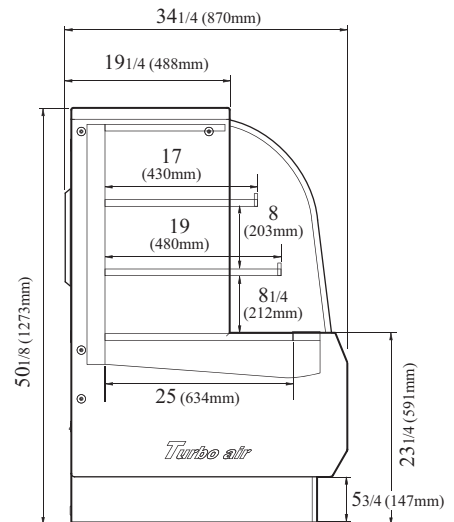

SIDE VIEW

Ver.20190411



- Turbo Air : 800-627-0032 ■ GK : 800-500-3519
- Warranty : 800-381-7770 ■ AC : 888-900-1002