



(800) 343-6890

srscooks.com

SEATTLE
RESTAURANT
S ♦ T ♦ O ♦ R ♦ E



XG-37

ROTARY BAR
GLASSWASHER

Standard Features :

- Fill and dump style cycle uses less water and energy than traditional rotary glasswashers.
- Unit plugs into standard 120V electrical outlet for an easy installation.
- Computer controlled fill cycle allows for 75°F (24°C) rinse, providing clean glasses that are cool to the touch.
- The sliding cover and cold water rinse prevent steam from escaping during and after the cycle.
- Unique drainboard top provides integrated glassware landing area.
- Exclusive design with side notch provides space for three one-gallon chemical containers within the 24" by 24" foot print.
- Conveyor advance switch rotates conveyor one-half turn for easy loading and unloading of glassware.
- Covers and drainboard top are easily removable for cleaning access.
- Pre-programmed de-liming cycle for easy removal of mineral deposits during maintenance (de-liming agent must be added).
- Conveyor and stationary spray box are easily removed for cleaning and visual inspection.
- Automatic peristaltic metering pumps accurately dispense detergent, sanitizer, and rinse aid.



Unique drainboard top provides integrated glassware landing area.

Covers and drainboard top are easily removable for cleaning access.

The sliding cover prevents water and steam from escaping during operation and reduces operating noise. Additionally, the cold water rinse eliminates steam billowing out at the end of the cycle.

59% LESS WATER

Fill and dump style cycle results in up to 59% less water consumption than common industry rotary glasswashers.



Easy to clean membrane switch panel includes :

Conveyor advance switch that rotates conveyor one half turn for easy loading and unloading of glassware.

Priming switches for easy priming of chemical pumps.

De-liming cycle for easy removal of mineral deposits during maintenance (de-liming agent must be added).



No curtain and soft-start conveyor help to ensure no glasses tip over during operation.

Full 10" of clearance height for washing glassware and pitchers.

Can wash up to 18 glasses per minute, easily handling the output of multiple bartenders using typical glassware. (A complete cycle is 2 minutes, 15 seconds)



Durable water recirculating pump has stainless steel housing and impeller (shown with cover removed)

87% LESS ENERGY

Fill and dump operation means no maintenance heater and low utility bills.

Uses up to 87% less energy than common industry rotary glasswashers.

Virtually no idle energy use.

Pumped wash and rinse ensures water line pressure variances do not affect wash results.



XG-37 is equipped with a slide-out chemical bottle rack for easy access to chemical bottles.

The XG-37 has a fill and dump style cycle but the comparisons to traditional fill & dump style machines end there. In addition to the cold water rinse, this glasswasher is specifically designed to align with underbar equipment. It also has a sliding cover for access to glassware, which improves bartender work flow by eliminating the door extending into the aisle.

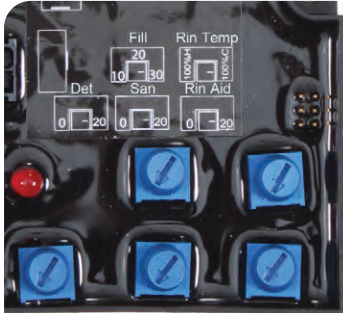

Control board

Delays cycle start until incoming water is at least 120°F (49°C) to ensure excellent wash results.

Allows lengthened fill time without increasing overall cycle time for installations with less than normal water volume.

Allows 75°F (24°C) cold water rinse temperature for clean glasses that are cool to the touch.

Permits easy chemical pump adjustments.

Slide-out circuit board tray allows for easy service access.

Switch turns off the machine if the cover is slid open during the spray portion of the cycle to prevent over spray. The cycle resumes if the cover is closed within 30 seconds.

Removable front and side panels for easy service access.



Automatic peristaltic metering chemical pumps:

Front-mounted for easy visual inspection.

Accurately dispense detergent, sanitizer, and rinse aid.

Third chemical pump included for use with rinse aid to ensure no spotting.

Specifications :

General Plumbing [Hot water and cold water required]

- Plumb with 1/2" water supply. Adapt to 3/8" FMPT
- Minimum water pressure is 25 PSI
- Maximum water pressure is 100 PSI. Install water pressure regulator if line pressure is over 100 PSI. Water valve on unit has built-in strainer and flow control to provide consistent volume between 25 and 100 PSI
- Install separate water shut-off valve
- Unit has built-in air gap - vacuum breaker is not required
- Consumption is 3 gallons per cycle

Hot Water Supply

- Maximum temperature is 150°F (66°C)
- Minimum temperature is 130°F (54°C)

Cold Water Supply

- No minimum temperature requirement

Drain

- 1-1/2" tailpiece.
- Use open type floor drain for maximum drainage

Electrical

- 120V, single phase, 60Hz, 6-foot grounded cord included
- Dedicated 15 amp circuit recommended
- Power requirements - 3.5 amps

Detergent*

- Extra heavy duty, non-foaming, commercial liquid dishwashing detergent is required - .30% concentration
- Consult local chemical supplier to match detergent with local water conditions

Sanitizer*

- Liquid chlorine bleach (sodium hypochlorite - 5.25% solution) adjusted to 50 ppm

Rinse Aid*

- Liquid Rinse Aid adjusted for proper sheeting

* Detergent, Sanitizer, and Rinse Aid containers are stored externally. The side cut-out in the machine provides space for three one-gallon chemical containers within the 24" x 24" foot print of the machine.

Operation / Capacity

- 120°F (49°C) minimum wash temp and rinse temp adjustable down to 75°F (24°C)
- 2 minute 15 second cycle
- 2-3/4" diameter bar glasses - 41 per cycle
- 2-1/2" diameter bar glasses - 49 per cycle
- Maximum glass height 10"

Materials

- 20 gauge stainless steel parts include: cabinet
- 18 gauge stainless steel parts include: floor and tanks
- 16 gauge stainless steel parts include: leg mounting brackets and legs
- 11 gauge stainless steel parts include: drive wheel

Service Access

Front panel is removable for service

Optional Accessory

- Export transformer 220V/50Hz electrical (price on request)



Drain stopper is controlled by a quiet and reliable gear motor with linkage cam instead of a noisy solenoid valve.



Conveyor easily lifts out for cleaning access.



Chemical fill is easily visible by sliding the cover open during the fill portion of the wash and rinse cycle.



Special mounting bracket allows for easy service access to water recirculating pump.



Incoming water line has built-in air gap so no separate vacuum breaker accessory is required.



Stationary spray box simply unlatches for easy visual inspection and cleaning.

Dimensions :

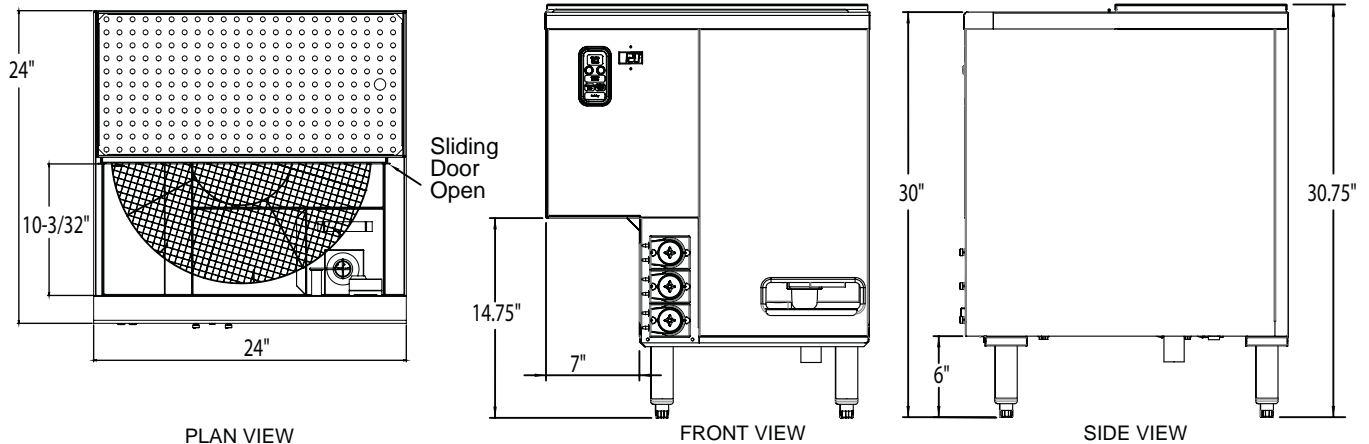

Mechanicals :

NOTE: 1. In all cases, consult local plumbing, electrical and health codes for regulations which may not be consistent with the information on the front of this specification sheet

2. The utility connections are made from the floor at the bottom of the unit approximately 7" to 8" high.

3. The Jet-Tech policy of constant quality improvement means specifications are subject to change without notice.

- ① = DRAIN
- ② = HOT WATER
- ③ = COLD WATER
- ④ = ELECTRICAL

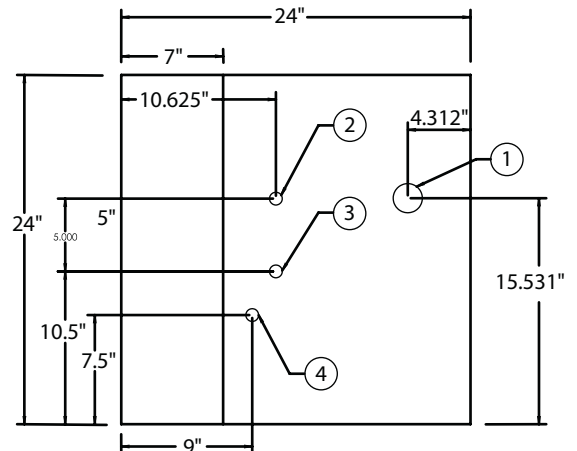

MVP GROUP CORPORATION
 5659 Royalmount Ave. Montreal QC, Canada H4P 2P9
 Tel: 514.737.9701 / 888.275.4538
 Fax: 514.342.3854 / 877.453.8832
 sales@mvpgroupcorp.com www.mvpgroupcorp.com