

## PPSL-14 Compact Manual Slicer

### Standard Features

- 14" special alloy knife (Rasspe®, high quality brand made in Italy), longer lasting and easier to sharpen
- 1/2HP knife motor with permanently lubricated ball bearings, overload protection
- Aluminum alloy one-piece base with stain resistant and easy clean anodized finish
- Top mounted, removable all metal knife sharpener with two stones for a razor sharp cutting edge
- Index knob control gets 0 to 9/16" (14mm) precision slice thickness adjustment
- Permanent ring guard protects entire non-slicing portion of the knife, with removable cover and deflector
- Knife cover interlock prevents slicer from operating without knife cover in place
- Sealed splash zones for added sanitation and protection of electronics
- Angled gravity feed food chute
- Power switch secures no voltage release preventing inadvertent reactivation of slicer in the event of power or interlock interruption.
- High quality aluminum for all base, food chute and feet.

PPSL-14 FRONT VIEW



PPSL-14 ANGLE



Model	Cheese Slicing Capacity	Overall Dimension				
		A	B	C	D	E
PPSL-14	Full Capacity	416 (16.36")	538 (21.")	722 (28.5")	604 (23.75")	874 (34.5")
Blade Diameter	Slicing Volume Per Day/Hr	Motor Power Watt/HP)	Slicer Thickness (mm)	Cut Capacity DxW (mm)	Net Weight KG/LBS	Package Size (cm)
350 mm/14" in	3	370w/1/2HP	0-14 (9/16")	210x270	46/101	69x57x53.5



1 YRS WARRANTY ON ALL PARTS AND LABOR (US ONLY)



## PLAN VIEW PPSL-14

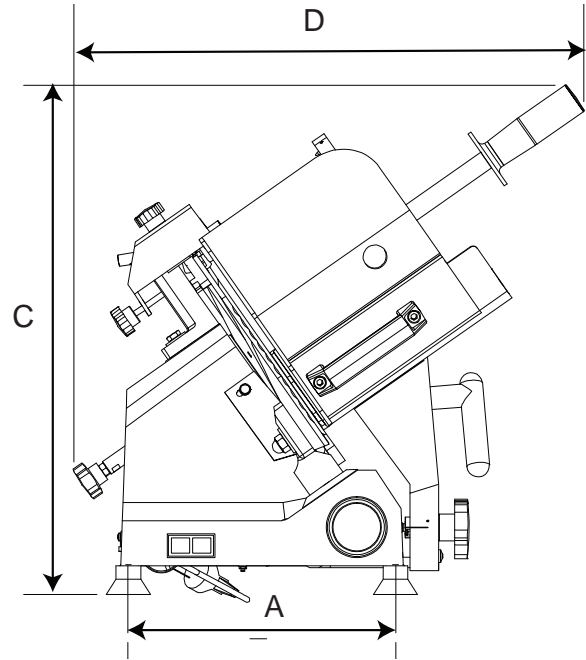
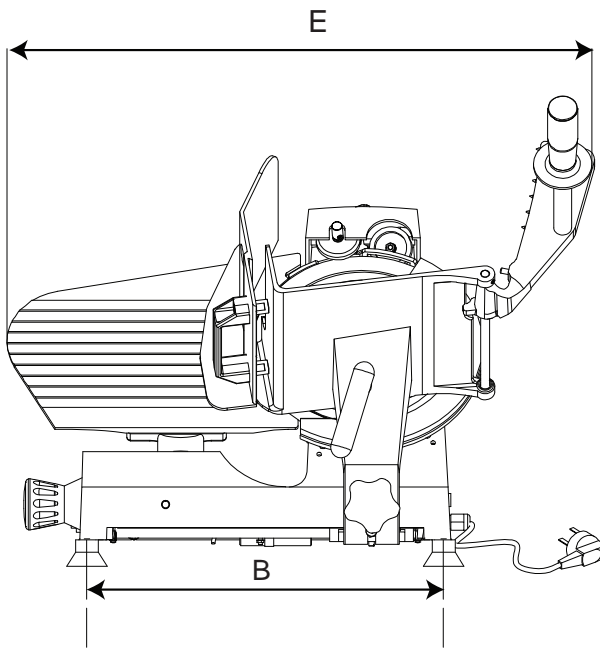

## Terms and Conditions

### 1 YEAR PARTS & LABOR WARRANTY

All claims for parts or labor must be made directly to Atosa. All claims must include: model number of the unit, serial number, proof of purchase, date of installation, and all pertinent information supporting the alleged defect. Failure to comply with warranty policies will result in voiding claims.

### WHAT IS WARRANTED AND FOR HOW LONG:

The Product's agitator, hub, and accessories are warranted not to fail as a result of defects in materials or workmanship in normal use for a period of one year from the date of purchase. Atosa agrees to repair or replace, at its option, the above warranted parts or items that fails due to defects in materials or workmanship during the warranted period. To obtain warranty service, the Purchaser must contact Atosa toll free (855) 855- 0399

Atosa warrants all new components and all parts, to be free from defects in materials or workmanship. Atosa's obligation under this warranty is limited to a period of one (1) year from the date of original installation or 12 months after shipment date from Atosa, whichever occurs first. All parts covered under this warranty that are defective within one (1) years of original installation or twelve (12) months after shipment date from manufacturer, whichever occurs first, are limited to repair or replacement (including labor charges, of defective parts or assemblies). The labor warranty shall include standard straight time labor charges only and reasonable travel time, as determined by Atosa.

### What is Not Covered by This Warranty

Changing Gears on the Mixers while Unit is Running and Overloading as Determined by an Approved Certified Technician. Atosa's sole obligation under this warranty is limited to either repair or replacement of parts, subject to the additional limitations below. This warranty neither assumes nor authorizes any person to assume obligations other than those expressly covered by this warranty. Changing Gears on the Mixers while Unit is Running and Overloading as Determined by an Approved Certified Technician. This warranty does not apply to, and Atosa is not responsible for any warranty claims on products sold or used outside of the contiguous United States.

### ROUTINE MAINTENANCE REQUIREMENTS MUST BE FOLLOWED

**OR WARRANTY IS VOID NO CONSEQUENTIAL DAMAGES:** ATOSA IS NOT RESPONSIBLE FOR ECONOMIC LOSS; PROFIT LOSS; OR SPECIAL, INDIRECT, OR CONSEQUENTIAL DAMAGES, INCLUDING WITHOUT LIMITATION, LOSSES, OR DAMAGES ARISING FROM FOOD OR PRODUCT SPOilage.

**WARRANTY IS NOT TRANSFERABLE:** This warranty is not assignable and applies only in favor of the original purchaser/user to whom delivered. ANY SUCH ASSIGNMENT OR TRANSFER SHALL VOID THE WARRANTIES HEREIN AND SHALL VOID ALL WARRANTIES, EXPRESS OR IMPLIED, INCLUDING ANY WARRANTY OF MERCHANTABILITY OR LABOR COVERAGE FOR COMPONENT FAILURE OR OTHER THE WARRANTY PACKET PROVIDED WITH THE UNIT.

**ALTERATION, NEGLECT, ABUSE, MISUSE, ACCIDENT, DAMAGE DURING TRANSIT OR INSTALLATION, FIRE, FOOD, OR ACTS OF GOD:** Atosa is not responsible for the repair or replacement of any parts that are determined to have been subjected after the date of manufacture to alteration, neglect, abuse, misuse, accident, damage during transit or installation, fire, flood, or act of God.

**IMPROPER ELECTRICAL CONNECTIONS:** Atosa IS NOT RESPONSIBLE FOR THE REPAIR OR REPLACEMENT OF FAILED OR DAMAGED COMPONENTS RESULTING FROM ELECTRICAL POWER FAILURE, THE USE OF EXTENSION CORDS, LOW VOLTAGE, OR VOLTAGE DROPS TO THE UNIT.

**THE ONE (1) YEAR PARTS & LABOR WARRANTY IS AS DESCRIBED ABOVE. THESE WARRANTIES ARE EXCLUSIVE AND IN LIEU OF ALL OTHER WARRANTIES, INCLUDING IMPLIED WARRANTY AND MERCHANTABILITY OR FITNESS FOR A PARTICULAR PURPOSE. THERE ARE NO WARRANTIES WHICH EXTEND BEYOND THE DESCRIPTION ON THE FACE HEREOF.**

Outside U.S. and Canada: This warranty does not apply to areas outside the continent of the United States. Alaska, Hawaii and all US territories are excluded from this warranty. Atosa is not responsible for any warranty claims made on products sold or used in such areas.

**\*In some cases, a 25 % restocking fee may be charged to a buyer for returned items.\***